

ECHOTEL®



SIL Safety Manual for Echotel® Model 961/962

Ultrasonic Level Switches



Model 961



Model 962

This manual complements and is intended to be used with the *Magnetrol Echotel® Model 961/962 Ultrasonic Single and Dual Point Level Switches Installation and Operating Manual* (Bulletin 51-646).

Application

Echotel® Model 961/962 ultrasonic level switches utilize pulsed signal technology to detect high, low, or dual-point level in a broad range of liquid media applications. The advanced self-test technology provides reliability and continuous testing of electronics, transducer, piezoelectric crystals, and electromagnetic noise.

Benefits

The Echotel Model 961/962 ultrasonic level switches provide the following benefits:

- Single- or dual-point liquid level measurement
- Adjustable time-delay for turbulent aerated liquids
- Reliable liquid level measurement independent of changes in media density, conductivity, or temperature
- Two-wire mA current shift and relay output options
- Relay output or mA current shift with separate malfunction indication
- Integral or remote mount electronics
- Pulsed signal technology
- Extensive hazardous location certifications
- Suitable for Safety Integrity Level (SIL) 2 loops



MAGNETROL®

AMETEK®

Echotel® Model 961/962 Ultrasonic Level Switches

Table of Contents

| | | | |
|--|----------|---|-----------|
| 1.0 Introduction | 3 | 6.0 Recurrent Function Tests | 10 |
| 1.1 Product Description | 3 | 6.1 Proof Testing | 10 |
| 1.2 Theory of Operation | 3 | 6.1.1 Introduction | 10 |
| 1.2.1 Transducer Design | 3 | 6.1.2 Interval | 10 |
| 1.2.2 Transducer Materials | 4 | 6.1.3 Recording Results | 10 |
| 1.3 Determining Safety Integrity Level (SIL) | 4 | 6.1.4 Suggested Proof Test | 10 |
| 2.0 Applicable Models | 4 | 6.1.5 Proof Test Coverage | 18 |
| 3.0 Mean Time To Repair (MTTR) | 4 | 7.0 Appendices | 19 |
| 4.0 Supplementary Documentation | 5 | 7.1 SIL Summary | 19 |
| 5.0 Instructions | 5 | 7.2 FMEDA Report | 20 |
| 5.1 Systematic Limitations | 5 | 7.2.1 FMEDA Report: | |
| 5.1.1 Application Locations | 5 | Management Summary | 21 |
| 5.1.2 Operating Temperature | 5 | 7.3 Lifetime of Critical Components | 23 |
| 5.1.3 Operating Pressure | 5 | | |
| 5.2 Skill Level of Personnel | 6 | | |
| 5.3 Necessary Tools | 6 | | |
| 5.4 Installation | 6 | | |
| 5.5 Configuration | 7 | | |
| 5.5.1 Time-delay Potentiometer | 7 | | |
| 5.5.2 High/Low DIP Switch | 7 | | |
| 5.5.3 Malfunction Test Push Button | 7 | | |
| 5.5.4 High/Low DIP Switch | 7 | | |
| 5.5.5 Independent/Joint DIP Switch | 7 | | |
| 5.5.6 Loop Test Push Button | 8 | | |
| 5.5.7 Fault Test Push Button | 8 | | |
| 5.5.8 22/3.6 DIP Switch | 8 | | |
| 5.6 Site Acceptance Testing | 9 | | |
| 5.7 Maintenance | 9 | | |
| 5.7.1 Diagnostics | 9 | | |
| 5.7.2 Troubleshooting | 9 | | |

1.0 Introduction

1.1 Product Description

Echotel® Model 961 and 962 ultrasonic level switches utilize pulsed signal technology to detect high, low, or dual point level in a broad range of liquid media applications.

Model 961 is a single-point level switch. Model 962 is a dual-point switch used as a level controller or to control pumps in an auto-fill or auto-empty mode.

Both Model 961 and 962 switches are suitable for use in Safety Integrity Level (SIL) 2 loops.

1.2 Theory of Operation

Model 961/962 switches utilize ultrasonic energy to detect the presence or absence of liquid in a single or dual point transducer. Ultrasonic contact level technology uses high-frequency sound waves that are easily transmitted across a transducer gap (see Figure 1) in the presence of a liquid media, but are attenuated when the gap is dry. Model 961/962 switches use an ultrasonic frequency of 2 MHz to perform this liquid level measurement in a wide variety of process media and application conditions.

The transducer uses a pair of piezoelectric crystals that are encapsulated in epoxy at the tip of the transducer. The crystals are made of a ceramic material that vibrates at a given frequency when subjected to an applied voltage. The transmit crystal converts the applied voltage from the electronics into an ultrasonic signal. When liquid is present in the gap, the receive crystal senses the ultrasonic signal from the transmit crystal and converts it back to an electrical signal. This signal is sent to the electronics to indicate the presence of liquid in the transducer gap. When there is no liquid present, the ultrasonic signal is attenuated and is not detected by the receive crystal.

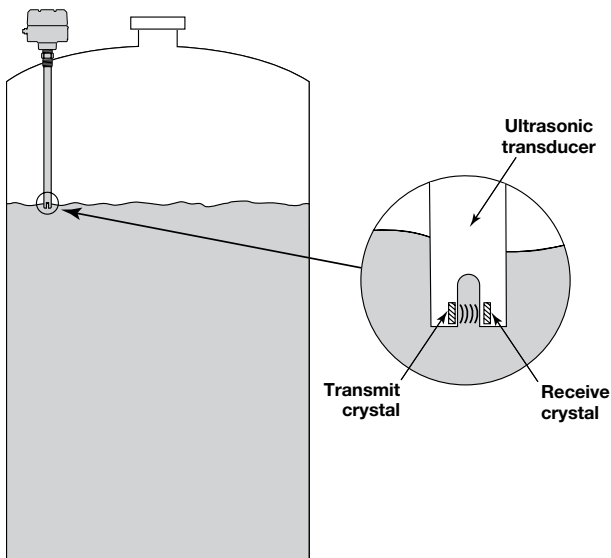

Figure 1
Ultrasonic Signal Transmission
Across Transducer Gap

1.2.1 Transducer Design

Magnetrol's advanced transducer design performs in difficult process conditions. Model 961 has a tip-sensitive transducer with an arched gap increasing its performance in aerated or foamy liquids. Model 962 has a tip-sensitive lower gap and flow-through upper gap permitting separations of 125 inches (318 cm).

1.2.2 Transducer Materials

A broad selection of transducer materials is available for the Model 961/962. Metallic transducers include 316 SS, Hastelloy® C, and Monel®. The 316 SS transducer has a NACE construction option for sour gas service, and can also be built per ASME B31.1 and B31.3 piping codes. Thermoplastic transducers include Kynar® and CPVC. These corrosion resistant plastic transducers feature a stiffening tube that runs the length of the transducer for extra rigidity. Kynar-faced 316 SS flange options are offered with the Kynar transducers.

1.3 Determining Safety Integrity Level (SIL)

The FMEDA report provides the failure rates and information for the PFDavg and Architecture Constraint.

The architecture constraint was determined using the 2H approach according to 7.4.4.3 of IEC 61508-2, 2010 edition. The Model 961/962 meets the hardware architecture constraints for up to SIL 2 at HFT=0 (or SIL 3 at HFT=1) when the failure rates listed in the FMEDA report are used.

Table 1
SIL vs. PFDavg

| Safety Integrity Level (SIL) | Target Average Probability of Failure on Demand (PFDavg) |
|------------------------------|--|
| 4 | $\geq 10^{-5}$ to $< 10^{-4}$ |
| 3 | $\geq 10^{-4}$ to $< 10^{-3}$ |
| 2 | $\geq 10^{-3}$ to $< 10^{-2}$ |
| 1 | $\geq 10^{-2}$ to $< 10^{-1}$ |

2.0 Applicable Models

This manual is applicable to the following models of the Echotel ultrasonic level switches with current shift output:

- Model 961 Single-Point Level Switches
- Model 962 Dual-Point Level Switches

3.0 Mean Time To Repair (MTTR)

SIL determinations are based on a number of factors including the Mean Time To Repair (MTTR). The analysis for the Echotel Model 961/962 ultrasonic level switch is based on a MTTR that is dependent on the end-user practices.

4.0 Supplementary Documentation

Refer to the following documents as supplements to this Echotel Model 961/962 SIL Safety Manual:

- *Echotel Model 961/962 Ultrasonic Level Switches Installation and Operating Manual* (Bulletin 51-646)
- Failure Modes, Effects and Diagnostics Analysis (FMEDA) exida Report No.: MAG 17/10-006 R001
Version V2, Revision R0, August 17, 2018

NOTE: The Failure Modes, Effects, and Diagnostic Analysis (FMEDA) report can be found in the Downloads tab of the Echotel 961/962 site page on ametech-measurement.com.

5.0 Instructions

5.1 Systematic Limitations

The following application and environmental limitations must be observed to avoid systematic failures.

5.1.1 Application Locations

The Model 961/962 ultrasonic level switch should be located for easy access for service, configuration, and monitoring. There should be sufficient headroom to allow installation and removal of the unit. Special precautions should be made to prevent exposure to corrosive atmosphere, excessive vibration, shock, or physical damage.

5.1.2 Operating Temperature

The ambient temperature range for the 961/962 electronics is -40 to +160 °F (-40 to + 70 °C). The operating temperature for the transducer is dependent on transducer material.

Table 2
9A1/9M1 Transducer Operating Temperatures

| | |
|---|---------------------------------|
| 316 Stainless Steel, Hastelloy C, and Monel | -40 to +325 °F (-40 to +163 °C) |
| Kynar | -40 to +250 °F (-40 to +121 °C) |
| CPVC | -40 to +180 °F (-40 to +82 °C) |

5.1.3 Operating Pressure

Maximum operating pressures are dependent on the transducer material. Refer to Section 3.4 in the *Echotel Model 961/962 Ultrasonic Level Switches Installation and Operating Manual* (Bulletin 51-646).

5.2 Skill Level of Personnel

Personnel following the procedures of this safety manual should have technical expertise equal to or greater than that of a qualified instrument technician.

5.3 Necessary Tools

No special equipment or tools are required to install Echotel Model 961/962 ultrasonic level switch. The following items are recommended:

- Wrenches, flange gaskets, and flange bolting appropriate for process connection(s)
- Screwdrivers and assorted tools for making conduit and electrical connections
- Digital multimeter or DVM for troubleshooting

5.4 Installation

The Model 961 single point switch may be used for high or low level alarm, overfill protection, or seal pot level and pump protection. Model 961 can be mounted vertically or horizontally in vessels, bridles, or pipes.

The Model 962 dual point switch may be used to measure high/low, high/high, or low/low levels. It can be used as a level controller or to control pumps in an auto-fill or auto-empty mode. Model 962 must be top mounted.

Refer Figures 2–5 to the *Echotel Model 961/962 Ultrasonic Switches Installation and Operating Manual* (Bulletin 51.646) for the proper installation instructions.

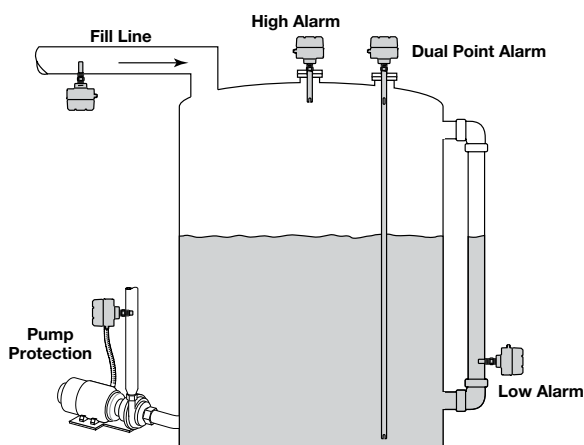

Figure 2
Typical Mounting Orientations

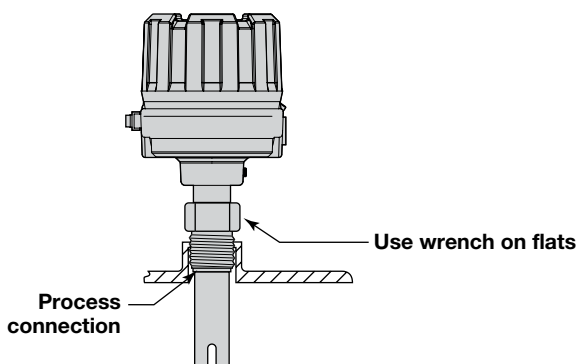

Figure 3
Typical Mounting Orientations

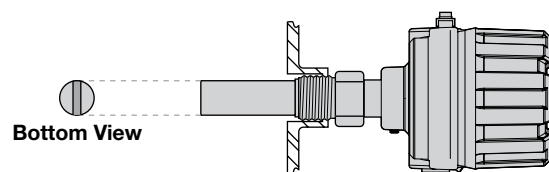

Figure 4
Horizontal Mounting

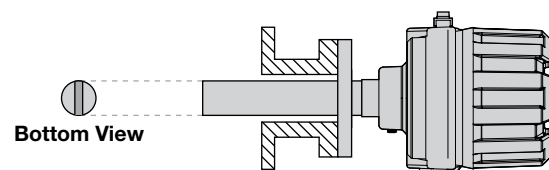

Figure 5
Nozzle Mounting

5.5 Configuration

Refer to Section 2.5 in the *Echotel Model 961/962 Ultrasonic Level Switches Installation and Operating Manual* (Bulletin 51-646) for complete configuration instructions.

5.5.1 Time-Delay Potentiometer

The time-delay potentiometer is used in applications where turbulence or splashing may cause false level alarm. The response time can be adjusted from factory-set standard of 0.5 seconds to a maximum of 10 seconds. The time-delay potentiometer is an option for both Model 961 and Model 962. The safety function must be designed so that it will operate correctly with the 961/962 set to maximum delay.

5.5.2 Level Test Push Button

The level test push button is used to manually test the DPDT process level relay and whatever is connected to the relay. Pressing this push button reverses the state of the DPDT relay from engaged to disengaged, or vice-versa. The level test push button is an option for both Model 961 and Model 962 in line-powered configuration only.

5.5.3 Malfunction Test Push Button

The malfunction test push button is used to manually test the SPDT malfunction relay and whatever is connected to the relay. Pressing and holding this push button for 2 seconds causes the SPDT relay to de-engage, indicating a fault condition. The malfunction test push button is an option for both the Model 961 and Model 962 in line-powered configuration only.

5.5.4 High/Low DIP Switch

The Hi/Lo DIP switch is used to select whether the switch is used as a high-level fail-safe or a low-level fail-safe switch. See Section 2.5 of the *Echotel Model 961/962 Ultrasonic Level Switches Installation and Operating Manual* (Bulletin 51-646) for high/low DIP switch configuration tables.

5.5.5 Independent/Joint DIP Switch

The I/J DIP switch is used to configure the SPDT malfunction relay to act independently or jointly with the DPDT process-level relay. In the factory-set I position, the SPDT and DPDT relays act independent of each other. In the J position, both the SPDT and DPDT relays will de-engage when a fault is detected. The I/J DIP switch is an option for the Model 961 in line-powered configuration only.

5.5.6 Loop Test Push Button

The loop test push button is used to manually test the loop current output. For Model 961, pressing the loop test push button reverses the output from 8 mA to 16 mA or from 16 mA to 8 mA. For Model 962, pressing the loop test push button changes the output from 8 mA to 12 mA, 12 mA to 16 mA, or 16 mA to 8 mA.

5.5.7 Fault Test Push Button

The fault test push button is used to manually change the mA values to that selected at the 22/3.6 DIP switch. Pressing this push button for two seconds simulates a circuit test failure. The output goes to the selected fault current of either 22 or 3.6 mA, and all three LEDs go dark. The fault test push button is an option on both Model 961 and Model 962.

5.5.8 22/3.6 DIP Switch

The 22/3.6 switch is used to produce a 22 mA or 3.6 mA output when the unit detects a fault. The 22/3.6 switch is on both the Model 961 and Model 962.

5.6 Site Acceptance Testing

Complete a site acceptance test to ensure proper operation after installation and configuration. Results of site acceptance testing must be recorded for future reference.

5.7 Maintenance

5.7.1 Diagnostics

Table 3
Diagnostic Push Buttons and LED Indications

| Electronics Version | Push Button | LED |
|------------------------|-------------|-------|
| 961 with 5 amp relays | LEVEL TEST | FAULT |
| 961 with current shift | LOOP TEST | FAULT |
| 962 with 5 amp relays | LEVEL TEST | FAULT |
| 962 with current shift | LOOP TEST | 16 mA |

Worst-case internal fault detection time is 10 seconds.

5.7.2 Troubleshooting

Report all failures to the AMETEK LMS Technical Support Department.

Refer to the Echotel Model 961/962 Ultrasonic Level Switches Installation and Operating Manual (Bulletin 51-646) for troubleshooting device errors.

- As there are no moving parts in this device, the only maintenance required is the SIL Proof Test.
- Firmware can only be upgraded by factory personnel.

Table 4
Troubleshooting Faults and Corrective Actions

| Flashes | Fault | Action |
|-----------|--|---|
| 1 flash | Indicates a problem with either the transducer, piezoelectric crystals, or the interconnection wiring. | Check wiring inside the housing to make sure that all wires are secure in their respective terminal blocks. Make sure that all the terminal block screws are fully tightened. If all wires are secure then contact the factory. Replace transducer if needed. Refer to Section 3.8 of the <i>Installation and Operating Manual</i> for proper replacement part numbers. |
| 2 flashes | Indicates a problem with one of the electronics boards. | Contact the factory for a replacement electronics module. Refer Section 3.8 of the <i>Installation and Operating Manual</i> for spare electronics modules part numbers. |
| 3 flashes | Indicates excessive levels of environmental noise. | Check if any source may be causing the interference, such as VFD (variable frequency drive), radiated electrical interference (two-way radio transceiver) or mechanical vibration from nearby source. |

6.0 Recurrent Function Tests

6.1 Proof Testing

6.1.1 Introduction

Following are the procedures utilized to detect Dangerous Undetected (DU) failures.

6.1.2 Interval

To maintain the appropriate Safety Integrity Level of a Safety Instrumented System, it is imperative that the entire system be tested at regular time intervals (shown as TI in the appropriate standards). The necessary time interval is determined by what is required to achieve the appropriate SIL level for PFD_{avg} .

NOTE: It is the responsibility of the owner/operator to select the type of inspection and the time period for these tests.

6.1.3 Recording Results

Results of the Proof Test should be recorded for future reference.

6.1.4 Suggested Proof Test

Suggested proof tests are provided for the relay and loop versions of the 961/962.

| Step | Proof Test – Echotel Model 961 Loop |
|---|--|
| Refer to the Model 961 installation and operation manual and the SIL Safety Manual (note the chart in section 2.5.2.4 of the I & O Manual). | |
| 1 | Bypass the PLC or take other action to avoid a false trip. |
| 2 | <p>Inspect the Unit in detail outside and inside for physical damage or evidence of environmental or process leaks</p> <p>a.) Inspect the exterior of the Unit housing. If there is any evidence of physical damage that may impact the integrity of the housing and the environmental protection, the unit should be repaired or replaced.</p> <p>b.) Inspect the interior of the Unit. Any evidence of moisture, from process or environment, is an indication of housing damage, and the unit should be repaired or replaced.</p> |
| 3 | <p>Observe and record the settings of the HI/LOW and 22/3.6 DIP switches, the LED indicators, Loop Current and Sensor GAP condition (WET or DRY).</p> <p>If the FAULT LED is lighted, diagnose the fault and repair or replace the unit.</p> <p>Confirm proper operation of the unit: WET/DRY GAP condition; 8mA LED or 16mA LED is lighted; Loop current = 8mA ±1mA or 16mA ±1 mA.</p> <p>a.) Press LOOP TEST push button and confirm change; 8mA >> 16mA or 16mA >> 8mA. Release the button and unit returns to proper operation.</p> <p>b.) Change HI/LOW DIP switch position. Confirm both LED & Loop Current change state; 8mA >> 16mA or 16mA >> 8mA. Observe the time delay from change of DIP switch until LED and Loop current change. Delay is set by Time Delay Pot, so delay may be as long as 15 seconds. Change HI/LOW DIP switch back to original setting and confirm proper operation, after the delay.</p> <p>c.) Press FAULT TEST push button and confirm: FAULT LED lights; Loop current ≥22mA or ≤3.6mA based on 22/3.6 switch. Release button.</p> <p>d.) Change the 22/3.6 DIP switch position. Press FAULT TEST push button and confirm: FAULT LED lights; Loop current ≥22mA or ≤3.6mA as expected. Release push button. Return 22/3.6 switch to original setting</p> <p>e.) Adjust the Time Delay Pot to maximum delay, fully clock-wise up to 20 turns. Change HI/LOW DIP switch position and observe the time delay from change of DIP switch until LED and Loop current change. Confirm delay ≥10 seconds. Change HI/LOW DIP switch back to original setting and confirm ≥10 seconds delay. Adjust the Time Delay Pot to minimum delay, fully counter-clock-wise ~20 turns. Change HI/LOW DIP switch position and observe the time delay. Confirm delay ≤1 seconds. Change HI/LOW DIP switch back to original setting and confirm minimum delay.</p> |
| 4 | <p>When possible moving the process level will provide a more complete proof test.</p> <p>Confirm proper operation of the unit: WET/DRY GAP condition; 8mA LED or 16mA LED is lighted; Loop current = 8mA ±1mA or 16mA ±1 mA.</p> <p>a.) Move the process level and confirm the GAP condition has changed. Confirm proper operation of the unit: WET/DRY GAP condition; 8mA LED or 16mA LED is lighted; Loop current = 8mA ±1mA or 16mA ±1 mA.</p> <p>b.) Move the process level and confirm the GAP condition has returned to original state. Confirm proper operation of the unit: WET/DRY GAP condition; 8mA LED or 16mA LED is lighted; Loop current = 8mA ±1mA or 16mA ±1 mA.</p> <p>c.) If unit fails the tests of steps 4a or 4b proceed to step 5.</p> <p>d.) Adjust the Time Delay Pot to the original setting. Use HI/LOW DIP switch (as described in step 2e) to confirm that delay is returned to original setting.</p> <p>e.) Proceed to step 6.</p> |

continued on next page

| Step | Proof Test – Echotel Model 961 Loop (continued) |
|------|---|
| 5 | <p>If the unit under test fails to respond to process level changes remove the unit from the process and bench test.</p> <ul style="list-style-type: none"> a.) Remove the unit from the process. Inspect the ultrasound transducer for evidence of damage or coating buildup. Fouling on the transducer surface may interfere with normal operation. If heavy fouling is evident, it is suggested to service the transducer more frequently. b.) Clean the ultrasonic transducer, especially in the area of the sensor GAP. c.) Perform a bench test per the steps of section 4. When possible it is best to use the actual process material, because material properties affect the ultrasonic performance. Confirm proper unit operation: WET/DRY GAP condition; 8mA LED or 16mA LED is lighted; Loop current = 8mA \pm1mA or 16mA \pm1mA d.) If unit passes the tests of steps 5c, return to the process installation and repeat the tests of step 4. e.) If the unit fails re-test in the process, it must be replaced. |
| 6 | Proof test is complete. Restore loop to full operation. |

| Step | Proof Test – Echotel Model 961 Relay |
|--|---|
| Refer to the Model 961 installation and operation manual and the SIL Safety Manual (note the charts in section 2.5.1 of the I & O Manual). | |
| 1 | Bypass the PLC or take other action to avoid a false trip. |
| 2 | <p>Inspect the Unit in detail outside and inside for physical damage or evidence of environmental or process leaks.</p> <p>a.) Inspect the exterior of the Unit housing. If there is any evidence of physical damage that may impact the integrity of the housing and the environmental protection, the unit should be repaired or replaced.</p> <p>b.) Inspect the interior of the Unit. Any evidence of moisture, from process or environment, is an indication of housing damage, and the unit should be repaired or replaced.</p> |
| 3 | <p>Observe and record the settings of the HI/LOW and INDEPENDENT/JOINT (I/J) DIP switches, the LED indicators, Relay contact conditions and Sensor GAP condition (WET or DRY).</p> <p>If the FAULT LED is lighted or the MALF LED is OFF, diagnose the fault and repair or replace the unit. Confirm proper operation of the unit: WET/DRY GAP condition and WET LED; LEVEL LED and relay operation.</p> <p>a.) Press LEVEL TEST push button and confirm Relay Contacts and LEVEL LED change state. Release the button and unit returns to proper operation based on the GAP condition and switch settings.</p> <p>b.) Change HI/LOW DIP switch position. Confirm LED & Relay change state. Observe the time delay from change of DIP switch until LED and Relay contacts change. Delay is set by Time Delay Pot, so delay may be as long as 10 seconds. Change HI/LOW DIP switch back to original setting and confirm proper operation, after the delay.</p> <p>c.) Press MALF TEST push button and confirm: FAULT LED lights, MALF and WET LEDs goes OFF and MALF Relay contacts go to the de-energized state. Release button. Confirm unit returns to normal operation</p> <p>d.) Adjust the Time Delay Pot to maximum delay, fully clock-wise up to 20 turns. Change HI/LOW DIP switch position and observe the time delay from change of DIP switch until LED and Relays change. Confirm delay ≥ 10 seconds. Change HI/LOW DIP switch back to original setting and confirm ≥ 10 seconds delay. Adjust the Time Delay Pot to minimum delay, fully counter-clockwise ~ 20 turns. Change HI/LOW DIP switch position and observe the time delay. Confirm delay ≤ 1 seconds. Change HI/LOW DIP switch back to original setting and confirm minimum delay.</p> |
| 4 | <p>When possible moving the process level will provide a more complete proof test. Confirm proper operation of the unit: WET/DRY GAP condition, WET LED and relay operation.</p> <p>a.) Move the process level and confirm the GAP condition has changed. Confirm proper operation of the unit: WET/DRY GAP condition and corresponding LED and Relay contacts state.</p> <p>b.) Return process level to original state. Confirm proper operation of the unit: WET/DRY GAP condition and corresponding LED and Relay contacts state.</p> <p>c.) If unit fails the tests of steps 4a or 4b proceed to step 5.</p> <p>d.) Adjust the Time Delay Pot to the original setting. Use HI/LOW DIP switch (as described in step 3b) to confirm that delay is returned to original setting.</p> <p>e.) Proceed to step 6.</p> |

continued on next page

| Step | Proof Test – Echotel Model 961 Relay (continued) |
|------|---|
| 5 | <p>If the unit under test fails to respond to process level changes remove the unit from the process and bench test.</p> <ul style="list-style-type: none"> a.) Remove the unit from the process. Inspect the ultrasound transducer for evidence of damage or coating buildup. Fouling on the transducer surface may interfere with normal operation. If heavy fouling is evident, it is suggested to service the transducer more frequently. b.) Clean the ultrasonic transducer, especially in the area of the sensor GAP. c.) Perform a bench test per the steps of section 4. When possible it is best to use the actual process material, because material properties affect the ultrasonic performance. Confirm proper unit operation: WET/DRY GAP condition; LEDs and Relay contacts state. d.) If unit passes the tests of steps 5c, return to the process installation and repeat the tests of step 4. e.) If the unit fails re-test in the process, it must be replaced. |
| 6 | Proof test is complete. Restore loop to full operation. |

| Step | Proof Test – Echotel Model 962 Loop |
|------|---|
| | Refer to the Model 962 installation and operation manual and the SIL Safety Manual (note the chart in section 2.5.4.4 of the I & O Manual). |
| 1 | Bypass the PLC or take other action to avoid a false trip. |
| 2 | <p>Inspect the Unit in detail outside and inside for physical damage or evidence of environmental or process leaks.</p> <p>a.) Inspect the exterior of the Unit housing. If there is any evidence of physical damage that may impact the integrity of the housing and the environmental protection, the unit should be repaired or replaced.</p> <p>b.) Inspect the interior of the Unit. Any evidence of moisture, from process or environment, is an indication of housing damage, and the unit should be repaired or replaced.</p> |
| 3 | <p>Observe and record the settings of the HI/LOW and 22/3.6 DIP switches, the LED indicators, Loop Current and Sensor GAP conditions (WET or DRY).</p> <p>If the FAULT condition is indicated by loop current and LED indicators all OFF, diagnose the fault and repair or replace the unit.</p> <p>Confirm proper operation of the unit: WET/DRY GAP conditions; 8mA LED, 12mA or 16mA LED is lighted; Loop current = 8mA ±1mA, 12mA ±1mA or 16mA ±1 mA.</p> <p>a.) Press LOOP TEST push button and confirm change; 8mA >> 12mA, 12mA >> 16mA or 16mA >> 8mA. Release the button and unit returns to proper operation.</p> <p>b.) Change HI/LOW DIP switch position. Confirm both LED & Loop Current change state; 8mA >> 16mA or 16mA >> 8mA. Note that 12mA will stay at 12mA with the switch change. Observe the time delay from change of DIP switch until LED and Loop current change. Delay is set by Time Delay Pot, so delay may be as long as 12 seconds. Press LOOP TEST push button and confirm change; 8mA >> 12mA, 12mA >> 16mA or 16mA >> 8mA. Release the button and unit returns to proper operation. Change HI/LOW DIP switch back to original setting and confirm proper operation, after the delay.</p> <p>c.) Press FAULT TEST push button and confirm: all LEDs go OFF; Loop current ≥22mA or ≤3.6mA based on 22/3.6 switch. Release button.</p> <p>d.) Change the 22/3.6 DIP switch position. Press FAULT TEST push button and confirm: all LEDs go OFF; Loop current ≥22mA or ≤3.6mA as expected. Release push button. Return 22/3.6 switch to original setting.</p> <p>e.) Adjust the Time Delay Pot to maximum delay, fully clock-wise up to 20 turns. Change HI/LOW DIP switch position and observe the time delay from change of DIP switch until LED and Loop current change. Confirm delay ≥10 seconds. Change HI/LOW DIP switch back to original setting and confirm ≥10 seconds delay. Adjust the Time Delay Pot to minimum delay, fully counter-clock-wise ~20 turns. Change HI/LOW DIP switch position and observe the time delay. Confirm delay ≤1 seconds. Change HI/LOW DIP switch back to original setting and confirm minimum delay.</p> |

continued on next page

| Step | Proof Test – Echotel Model 962 Loop (continued) |
|------|--|
| 4 | <p>Move the process level to achieve three possible states: 1. both GAPS DRY, 2. one GAP DRY & one GAP WET, 3. Both GAPS WET. This test confirms operation with all GAP states.</p> <p>Confirm proper operation of the unit: WET/DRY GAP conditions; 8mA LED, 12mA or 16mA LED is lighted; Loop current = 8mA \pm1mA, 12mA \pm1mA or 16mA \pm1mA.</p> <ul style="list-style-type: none"> a.) Move the process level to achieve state 1. Both GAPS DRY. Confirm proper operation of the unit: WET/DRY GAP conditions; 8mA LED or 16mA LED is lighted; Loop current = 8mA \pm1mA or 16mA \pm1 mA. b.) Move the process level to achieve state 2. one GAP DRY and one GAP WET. Confirm proper operation of the unit: WET/DRY GAP conditions; 12mA LED is lighted; Loop current = 12mA \pm1mA. c.) Move the process level to achieve state 3. Both GAPS WET. Confirm proper operation of the unit: WET/DRY GAP conditions; 8mA LED or 16mA LED is lighted; Loop current = 8mA \pm1mA or 16mA \pm1 mA. d.) If unit fails the tests of steps 4a 4b or 4c proceed to step 5. e.) Adjust the Time Delay Pot to the original setting. Use HI/LOW DIP switch (as described in step 2e) to confirm that delay is returned to original setting. f.) Proceed to step 6. |
| 5 | <p>If the unit under test fails to respond to process level changes remove the unit from the process and bench test.</p> <ul style="list-style-type: none"> a.) If the unit under test fails to respond to process level changes remove the unit from the process and bench test. b.) Clean the ultrasonic transducer, especially in the area of the sensor GAPS. c.) Perform a bench test per the steps of section 4. When possible it is best to use the actual process material, because material properties affect the ultrasonic performance. Confirm proper unit operation: WET/DRY GAP conditions; 8mA LED, 12mA LED or 16mA LED is lighted; Loop current = 8mA \pm1mA, 12ma \pm1mA or 16mA \pm1mA. d.) If unit passes the tests of steps 5c, return to the process installation and repeat the tests of step 4. e.) If the unit fails re-test in the process, it must be replaced. |
| 6 | <p>Proof test is complete. Restore loop to full operation.</p> |

| Step | Proof Test – Echotel Model 962 Relay |
|--|--|
| Refer to the Model 962 installation and operation manual and the SIL Safety Manual (note the charts in section 2.5.3 of the I & O Manual). | |
| 1 | Bypass the PLC or take other action to avoid a false trip. |
| 2 | <p>Inspect the Unit in detail outside and inside for physical damage or evidence of environmental or process leaks.</p> <p>a.) Inspect the exterior of the Unit housing. If there is any evidence of physical damage that may impact the integrity of the housing and the environmental protection, the unit should be repaired or replaced.</p> <p>b.) Inspect the interior of the Unit. Any evidence of moisture, from process or environment, is an indication of housing damage, and the unit should be repaired or replaced.</p> |
| 3 | <p>Observe and record the settings of the HI/LOW and PUMP CONTROL/LEVEL CONTROL (PC/LC) DIP switches, the LED indicators, Relay contact conditions and Sensor GAP condition (WET or DRY). If the FAULT LED is lighted or the MALF LED is OFF, diagnose the fault and repair or replace the unit. Confirm proper operation of the unit: WET/DRY GAP condition for each GAP; UPPER LED and relay operation; and LOWER LED and relay operation.</p> <p>a.) Press LEVEL TEST push button and confirm both UPPER and LOWER Relay Contacts change state, and LEDs also change. Release the button and unit returns to proper operation based on the GAP condition and switch settings.</p> <p>b.) Change HI/LOW DIP switch position. Confirm LEDs & Relays change state. Observe the time delay from change of DIP switch until LEDs and Relay contacts change. Delay is set by Time Delay Pot, so delay may be as long as 10 seconds. Change HI/LOW DIP switch back to original setting and confirm proper operation, after the delay.</p> <p>c.) Press MALF TEST push button and confirm: FAULT LED lights, All other LEDs goes OFF, and all Relay contacts go to the de-energized state. Release button. Confirm unit returns to normal operation.</p> <p>d.) Adjust the Time Delay Pot to maximum delay, fully clock-wise up to 20 turns. Change HI/LOW DIP switch position and observe the time delay from change of DIP switch until LED and Relays change. Confirm delay ≥ 10 seconds. Change HI/LOW DIP switch back to original setting and confirm ≥ 10 seconds delay. Adjust the Time Delay Pot to minimum delay, fully counter-clock-wise ~ 20 turns. Change HI/LOW DIP switch position and observe the time delay. Confirm delay 1 seconds. Change HI/LOW DIP switch back to original setting and confirm minimum delay.</p> |
| 4 | <p>When possible moving the process level will provide a more complete proof test. Confirm proper operation of the unit: WET/DRY GAP condition for each GAP; UPPER LED and relay operation; and LOWER LED and relay operation.</p> <p>a.) Move the process level and confirm the GAP condition has changed. Confirm proper operation of the unit: WET/DRY GAP condition and corresponding LED and Relay contacts state. Continue to move process level in order to test three possible states; 1. Both GAPS DRY</p> <p>2. One GAP WET 3. BOTH GAPS WET.</p> <p>b.) Change the PUMP CONTROL / LEVEL CONTROL (PC/LC) DIP switch position. Repeat the test of step 4a to test all three possible GAP states and confirm expected operation. Return the PC/LC DIP to the original position.</p> <p>c.) If unit fails the tests of steps 4a or 4b proceed to step 5.</p> <p>d.) Adjust the Time Delay Pot to the original setting. Use HI/LOW DIP switch (as described in step 2e) to confirm that delay is returned to original setting.</p> <p>e.) Proceed to step 6.</p> |

continued on next page

| Step | Proof Test – Echotel Model 962 Relay (continued) |
|------|---|
| 5 | <p>If the unit under test fails to respond to process level changes remove the unit from the process and bench test.</p> <p>a.) Remove the unit from the process. Inspect the ultrasound transducer for evidence of damage or coating buildup. Fouling on the transducer surface may interfere with normal operation. If heavy fouling is evident, it is suggested to service the transducer more frequently.</p> <p>b.) Clean the ultrasonic transducer, especially in the area of the sensor GAP.</p> <p>c.) Perform a bench test per the steps of section 4. When possible it is best to use the actual process material, because material properties affect the ultrasonic performance. Confirm proper unit operation: WET/DRY GAP condition; LEDs and Relay contacts state.</p> <p>d.) If unit passes the tests of steps 5c, return to the process installation and repeat the tests of step 4.</p> <p>e.) If the unit fails re-test in the process, it must be replaced</p> |
| 6 | Proof test is complete. Restore loop to full operation. |

6.1.5 Proof Test Coverage

The Proof Test Coverages for the various product configurations is given in Table 5 and Table 6.

Table 5
Proof Test Coverage
961/962 Line Powered – Relay Output Version

| Device | λ_{DU}^{PT} (FIT) ⁶ | Proof Test Coverage |
|-------------------------------|---|---------------------|
| 961 Dry is Safe Redundant | 30 | 87% |
| 961 Wet is Safe Redundant | 50 | 78% |
| 961 Dry is Safe Non-Redundant | 55 | 93% |
| 961 Wet is Safe Non-Redundant | 76 | 84% |
| 962 Dry is Safe | 60 | 75% |
| 962 Wet is Safe | 96 | 72% |

Table 6
Proof Test Coverage
961/962 Loop Powered – Current Shift Version

| Device | λ_{DU}^{PT} (FIT) ⁶ | Proof Test Coverage |
|-----------------|---|---------------------|
| 961 Dry is Safe | 10 | 20% |
| 961 Wet is Safe | 27 | 63% |
| 962 Dry is Safe | 10 | 70% |
| 962 Wet is Safe | 47 | 87% |

7.0 Appendices

7.1 SIL Summary

The Echotel® Model 961/962 random capability information is summarized in Tables 6 and 7. FIT = Failure in Time (1×10^{-9} failures per hour).

Table 7
Relay Output Version

| Product | Model 961 Dry is Safe Non-redundant | Model 961 Wet is Safe Non-redundant | Model 961 Dry is Safe Redundant | Model 961 Wet is Safe Redundant | Model 962 Dry is Safe | Model 962 Wet is Safe |
|-------------------------------------|---|---|---------------------------------------|---------------------------------------|--------------------------------|--------------------------------|
| SIL Architecture Constraint (2H) | SIL 2 @ HFT=0 SIL 3 @ HFT=1 | SIL 2 @ HFT=0 SIL 3 @ HFT=1 | SIL 2 @ HFT=0 SIL 3 @ HFT=1 | SIL 2 @ HFT=0 SIL 3 @ HFT=1 | SIL 2 @ HFT=0 SIL 3 @ HFT=1 | SIL 2 @ HFT=0 SIL 3 @ HFT=1 |
| Device Type | B | B | B | B | B | B |
| λ_{sd} | 263 FITS | 15 FITS | 263 FITS | 15 FITS | 451 FITS | 24 FITS |
| λ_{su} | 199 FITS | 178 FITS | 186 FITS | 165 FITS | 226 FITS | 186 FITS |
| λ_{dd} | 28 FITS | 275 FITS | 28 FITS | 275 FITS | 39 FITS | 466 FITS |
| λ_{du} | 55 FITS | 76 FITS | 30 FITS | 50 FITS | 60 FITS | 96 FITS |

Table 8
Loop Version

| Product | Model 961 Dry is Safe | Model 961 Wet is Safe | Model 962 Dry is Safe | Model 962 Wet is Safe |
|-------------------------------------|--------------------------------|--------------------------------|--------------------------------|--------------------------------|
| SIL Architecture Constraint (2H) | SIL 2 @ HFT=0 SIL 3 @ HFT=1 | SIL 2 @ HFT=0 SIL 3 @ HFT=1 | SIL 2 @ HFT=0 SIL 3 @ HFT=1 | SIL 2 @ HFT=0 SIL 3 @ HFT=1 |
| Device Type | B | B | B | B |
| λ_{sd} | 0 FITS | 0 FITS | 0 FITS | 0 FITS |
| λ_{su} | 38 FITS | 20 FITS | 64 FITS | 26 FITS |
| λ_{dd} | 234 FITS | 234 FITS | 426 FITS | 426 FITS |
| λ_{du} | 10 FITS | 27 FITS | 10 FITS | 47 FITS |



Failure Modes, Effects and Diagnostic Analysis

Project:
ECHOTEL 961/962 Ultrasonic Single and Dual Point Level Switches

Company:
Magnetrol International, Inc.
Aurora, IL
USA

Contract Number: Q17/10-006
Report No.: MAG 17/10-006 R001
Version V2, Revision R0, August 17, 2018
Rudolf Chalupa

The document was prepared using best effort. The authors make no warranty of any kind and shall not be liable in any event for incidental or consequential damages in connection with the application of the document.
© All rights reserved.



Management Summary

This report summarizes the results of the hardware assessment in the form of a Failure Modes, Effects, and Diagnostic Analysis (FMEDA) of the ECHOTEL 961/962 Ultrasonic Single and Dual Point Level Switches, hardware and software revision per Section 2.5.1. A Failure Modes, Effects, and Diagnostic Analysis is one of the steps to be taken to achieve functional safety certification per IEC 61508 of a device. From the FMEDA, failure rates are determined. The FMEDA that is described in this report concerns only the hardware of the 961/962. For full functional safety certification purposes, all requirements of IEC 61508 must be considered.

ECHOTEL 961/962 Ultrasonic Single and Dual Point Level Switches utilize pulsed signal technology to detect high, low, or dual point level in a broad range of liquid media applications. Model 961 is a single point level switch. Model 962 is a dual point switch used as a level controller or to control pumps in an auto-fill or auto-empty mode.

Table 1 and Table 2 are an overview of the different versions that were considered in the FMEDA of the 961/962.

Table 1 Line Powered, Relay Output Version Overview

| | |
|-------------------------------|--|
| 961 Dry Is Safe Redundant | 961-2 or 961-7 Single Point Level Switch, Reported Dry Condition Is Safe, Redundant Relay Contacts |
| 961 Wet Is Safe Redundant | 961-2 or 961-7 Single Point Level Switch, Reported Wet Condition Is Safe, Redundant Relay Contacts |
| 961 Dry Is Safe Non-redundant | 961-2 or 961-7 Single Point Level Switch, Reported Dry Condition Is Safe, Non-redundant Relay Contacts |
| 961 Wet Is Safe Non-redundant | 961-2 or 961-7 Single Point Level Switch, Reported Wet Condition Is Safe, Non-redundant Relay Contacts |
| 962 Dry Is Safe | 962-2 or 962-7 Dual Point Level Switch, Reported Dry Condition Is Safe |
| 962 Wet Is Safe | 962-2 or 962-7 Dual Point Level Switch, Reported Wet Condition Is Safe |

Table 2 Loop Powered, Current Shift Version Overview

| | |
|-----------------|---|
| 961 Dry Is Safe | 961-5 Single Point Level Switch, Reported Dry Condition Is Safe |
| 961 Wet Is Safe | 961-5 Single Point Level Switch, Reported Wet Condition Is Safe |
| 962 Dry Is Safe | 962-5 Dual Point Level Switch, Reported Dry Condition Is Safe |
| 962 Wet Is Safe | 962-5 Dual Point Level Switch, Reported Wet Condition Is Safe |

The 961/962 is classified as a Type B¹ element according to IEC 61508, having a hardware fault tolerance of 0.

¹ Type B element: "Complex" element (using micro controllers or programmable logic); for details see 7.4.4.1.3 of IEC 61508-2, ed2, 2010.



The failure rate data used for this analysis meet the *exida* criteria for Route 2_H which is more stringent than IEC 61508. Therefore, the 961/962 meets the hardware architectural constraints for up to SIL 2 at HFT=0 (or SIL 3 @ HFT=1) when the listed failure rates are used.

Based on the assumptions listed in 4.3, the failure rates for the 961/962 are listed in section 4.4.

These failure rates are valid for the useful lifetime of the product, see Appendix A.

The failure rates listed in this report are based on over 250 billion-unit operating hours of process industry field failure data. The failure rate predictions reflect realistic failures and include site specific failures due to human events for the specified Site Safety Index (SSI), see section 4.2.2.

A user of the 961/962 can utilize these failure rates in a probabilistic model of a safety instrumented function (SIF) to determine suitability in part for safety instrumented system (SIS) usage in a particular safety integrity level (SIL).

7.3 Lifetime of Critical Components

According to Section 7.4.9.5 of IEC 61508-2, a useful lifetime, based on experience, should be determined and used to replace equipment before the end of useful life.

Although a constant failure rate is assumed by the exida FMEDA prediction method, this only applies provided that the useful lifetime* of components is not exceeded. Beyond their useful lifetime, the result of the probabilistic calculation method is likely optimistic, as the probability of failure significantly increases with time. The useful lifetime is highly dependent on the subsystem itself and its operating conditions.

Table 8 shows which components are contributing to the dangerous undetected failure rate and, therefore, to the PFDavg calculation and what their estimated useful lifetime is.

Table 9
Useful lifetime of components contributing to dangerous undetected failure rate

| Component | Useful Life |
|---|----------------------------|
| Capacitor (electrolytic) — Aluminum electrolytic, non-solid electrolyte | Approximately 90,000 hours |

It is the responsibility of the end user to maintain and operate the 961/962 per manufacturer's instructions. Furthermore, regular inspection should show that all components are clean and free from damage.

The limiting factors with regard to the useful lifetime of the system are the aluminum electrolytic capacitors. Therefore, the useful is predicted to be 10 years.

For high demand mode applications, the useful lifetime of the relays is limited by the number of cycles. The useful lifetime of the relay is > 100,000 full scale cycles or 8 to 10 years, whichever results in the shortest lifetime.

When plant/site experience indicates a shorter useful lifetime than indicated in this appendix, the number based on plant/site experience should be used.

** Useful lifetime is a reliability engineering term that describes the operational time interval where the failure rate of a device is relatively constant. It is not a term which covers product obsolescence, warranty, or other commercial issues.*

References

- IEC 61508 Edition 2.0.2010 “Functional Safety of Electrical/Electronic/Programmable Electronic Safety Related Systems”
- ANSI/ISA-84.00.01-2004 Part 1 (IEC 61511-1Mod) “Functional Safety: Safety Instrumented Systems for the Process Industry Sector–Part 1 Hardware and Software Requirements”
- ANSI/ISA-84.00.01-2004 Part 2 (IEC 61511-2Mod) “Functional Safety: Safety Instrumented Systems for the Process Industry Sector–Part 2 Guidelines for the Application of ANSI/ISA84.00.01-2004 Part 1 (IEC 61511-1 Mod)–Informative”
- ANSI/ISA-84.00.01-2004 Part 3 (IEC 61511-3Mod) “Functional Safety: Safety Instrumented Systems for the Process Industry Sector–Part 3 Guidance for the Determination of the Required Safety Integrity Levels– Informative”
- ANSI/ISA-TR84.00.04 Part 1 (IEC 61511 Mod) “Guideline on the Implementation of ANSI/ISA-84.00.01-2004”

ASSURED QUALITY & SERVICE COST LESS

Service Policy

Owners of Magnetrol controls may request the return of a control or any part of a control for complete rebuilding or replacement. They will be rebuilt or replaced promptly. Controls returned under our service policy must be returned by Prepaid transportation. Magnetrol will repair or replace the control at no cost to the purchaser (or owner) other than transportation if:

1. Returned within the warranty period; and
2. The factory inspection finds the cause of the claim to be covered under the warranty.

If the trouble is the result of conditions beyond our control; or, is NOT covered by the warranty, there will be charges for labor and the parts required to rebuild or replace the equipment.

In some cases it may be expedient to ship replacement parts; or, in extreme cases a complete new control, to replace the original equipment before it is returned. If this is desired, notify the factory of both the model and serial numbers of the control to be replaced. In such cases, credit for the materials returned will be determined on the basis of the applicability of our warranty.

No claims for misapplication, labor, direct or consequential damage will be allowed.

Return Material Procedure

So that we may efficiently process any materials that are returned, it is essential that a “Return Material Authorization” (RMA) number be obtained from the factory, prior to the material’s return. This is available through a Magnetrol local representative or by contacting the factory. Please provide the following information:

1. Company Name
2. Description of Material
3. Serial Number
4. Reason for Return
5. Application

Any unit that was used in a process must be properly cleaned in accordance with OSHA standards, before it is returned to the factory.

A Material Safety Data Sheet (MSDS) must accompany material that was used in any media.

All shipments returned to the factory must be by prepaid transportation.

All replacements will be shipped F.O.B. factory.



705 Enterprise Street • Aurora, Illinois 60504-8149 USA
630.969.4000 • info.magnetrol@ametek.com • ametek-measurement.com

Copyright © 2024 AMETEK Magnetrol USA, LLC

BULLETIN: 51-650.3
EFFECTIVE: March 2024
SUPERSEDES: February 2019